

12V C.C. - D.C.

VA01-AP70/LL-36A  
VA01-AP70/LL-36S



- N°4 BORCHIE - ALTEZZA H=7.5  
FORI Ø6.5 - INTERASSE Ø336.9 ±0.2  
- N°4 BOSSES - HEIGHT H=7.5  
HOLES Ø6.5 - INTERAXLE Ø336.9 ±0.2

- N°4 GANCI PER PERNI Ø6  
INTERASSE Ø340.1 ±0.2  
- N°4 HOOKS Ø6  
INTERASSE Ø340.1 ±0.2

SEDE PER ANELLO IN GOMMA  
RUBBER RING HOUSING

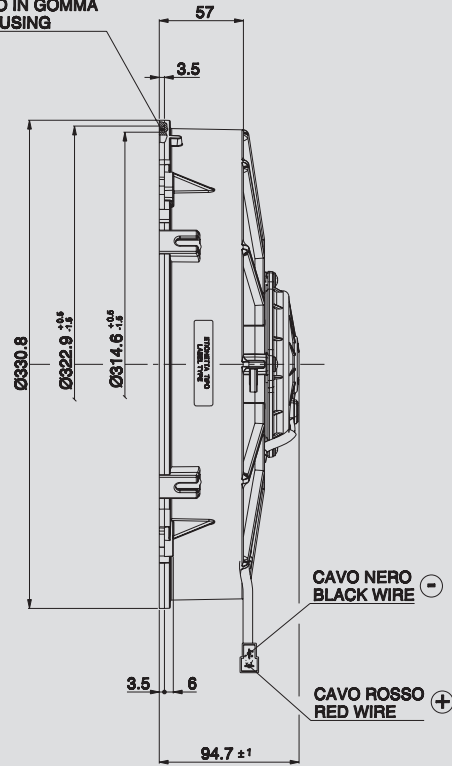
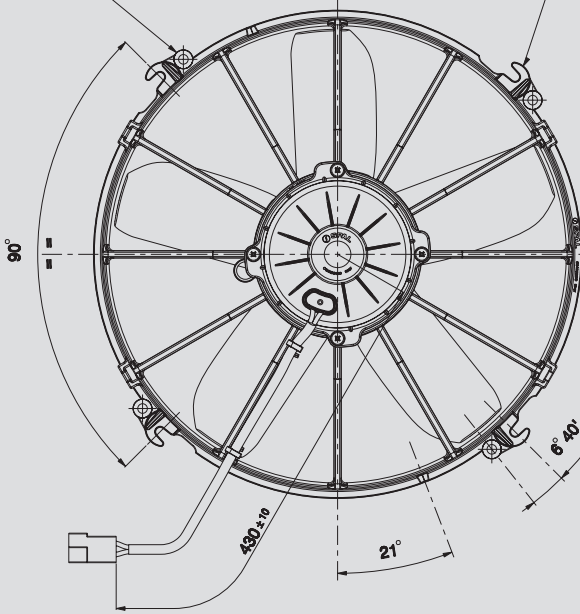

AMP connector Code 180908  
AMP terminal Code 42098-2  
Suggested mounting torque: 3(+1/-0) Nm with screw M5  
Weight 2,35 Kg. approx.

Connettore AMP Cod. 180908  
Terminali AMP Cod. 42098-2  
Coppia di serraggio consigliata: 3(+1/-0) Nm con vite M5  
Peso 2,35 Kg. circa

Ø 305 mm  
Ø 12"

suction / aspirante

blowing / soffiante

PRODUCT FEATURES  
CARATTERISTICHE PRODOTTO

Static pressure Pressione statica mm H <sub>2</sub> O	suction / aspirante			blowing / soffiante			Static pressure Pressione statica in H <sub>2</sub> O
	Airflow Portata m <sup>3</sup> /h	Current input Corrente assorbita A	Airflow Portata CFM	Airflow Portata m <sup>3</sup> /h	Current input Corrente assorbita A	Airflow Portata CFM	
0	2780	13,9	1640	2860	13,9	1687	0
5	2490	15,2	1469	2560	14,8	1510	0,2
10	2120	16,0	1251	2280	15,8	1345	0,4
15	1600	15,9	944	1920	16,6	1133	0,6
20	1020	16,7	602	1360	17,1	802	0,8
25	730	18,0	431	890	17,8	525	1
30	510	18,9	301	500	18,5	295	1,2
35	160	20,5	94	0	21,0	0	1,4
40	0	21,8	0				1,6

Waterproof motor, IP 68 Motore chiuso, IP 68	✓
Long life / Lunga durata	✓
VLL version* / Versione VLL*	✓
Waterproof connector Connettori a tenuta stagna	✓
Accessories: all the fixing kits Accessori: tutti i kit di fissaggio	✓

\* for OEM applications only.  
\* per applicazioni OEM

✓ = Standard feature  
Caratteristiche standard  
✓ = Available upon request  
Disponibile su richiesta

Test voltage 13 V. d.c. - Tensione di prova 13 V. c.c.